

For Fuel Tanks 6" - 12" Deep
For Fuel Tanks 4" - 24" Deep



Electric Fuel Sender Installation Instructions

Will work with any dash mounted gauges calibrated to 240 - 33 ohm's. These senders have been 100% tested to ensure full range of readings. May be used for Diesel if separate return line is available. **NOT FOR USE WITH WATER**

⚠ WARNING

Gasoline is **EXTREMELY FLAMMABLE**. Make certain the tank is empty and work area is well ventilated before starting.

⚠ WARNING

If uncertain how to perform any procedures, including wiring, seek the help from a qualified individual.

Installation:

1. Disconnect battery and any other electrical sources.
2. Remove the existing sending unit.

⚠ CAUTION

Please observe the screw hole pattern to the direction of the float arm. Failure to do so may result in interference with the tank wall.

3. **Adjusting bracket for 4" - 24" senders** (for 6" - 12" senders, skip to step 5): Measure the depth of the tank. Measuring from the bottom of the sending unit's mounting plate, mark the bracket at 1/2 of the tank depth plus 1/2" and cut the bracket. (See Fig. 1)
4. Attach the float arm to the bracket 1/8" from the bottom of the bracket with two self-tapping screws. (See Fig. 2)

5. **Adjusting float arm length:** For 6" - 24" senders use **Table 1**. For 6" - 12" senders use **Table 2**. Look up the measured tank depth dimension, find the correct float arm length "B" (If exact tank depth is not listed, use the next highest depth.) and mark the correct length on the stainless steel float arm. For under 6" see Fig. 1.

6. Slide float and push-on fasteners toward float arm axle until outer end of float is 3/16" less than dimension "B".
7. Cut float arm at dimension "B".
8. If the sending unit does not match the old unit's arm position in relation to the screw hole pattern, loosen the nut at the top of the new sender. Rotate the mounting plate 90° until the new sender matches the position of the old unit. Re-tighten the nut on top of the new sender to 15 in. lbs. (See Fig. 3)

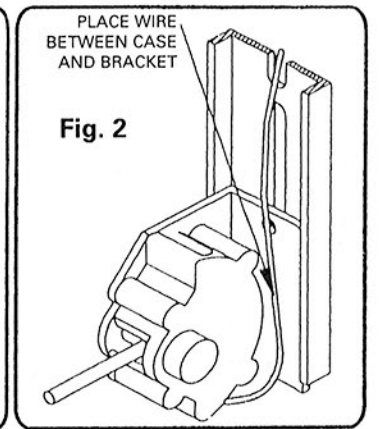
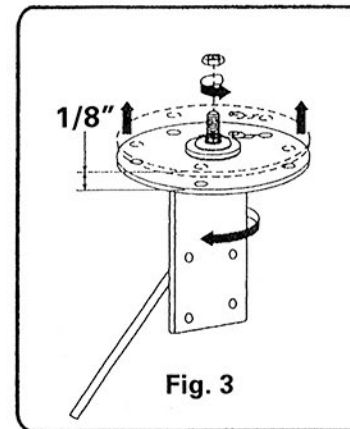
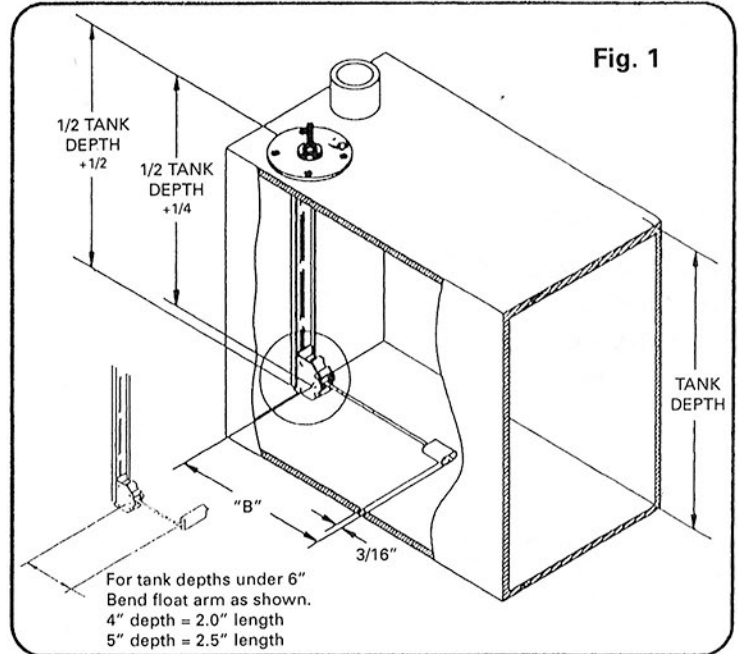

TABLE 1

TANK DEPTH	FLOAT ARM LENGTH "B"	TANK DEPTH	FLOAT ARM LENGTH "B"	TANK DEPTH	FLOAT ARM LENGTH "B"
INCHES (MM)	INCHES (MM)	INCHES (MM)	INCHES (MM)	INCHES (MM)	INCHES (MM)
6 (152)	3-5/8 (92)	12-1/2 (318)	8-1/4 (210)	19 (483)	12-7/8 (327)
6-1/2 (165)	4 (102)	13 (330)	8-5/8 (219)	19-1/2 (495)	13-1/4 (337)
7 (178)	4-3/8 (111)	13-1/2 (343)	9 (229)	20 (508)	13-1/2 (343)
7-1/2 (191)	4-3/4 (121)	14 (356)	9-3/8 (238)	20-1/2 (521)	13-7/8 (352)
8 (203)	5-1/8 (130)	14-1/2 (368)	9-3/4 (248)	21 (533)	14-1/4 (362)
8-1/2 (216)	5-3/8 (137)	15 (381)	10 (254)	21-1/2 (546)	14-1/2 (368)
9 (229)	5-3/4 (146)	15-1/2 (394)	10-1/2 (267)	22 (559)	15 (381)
9-1/2 (241)	6-1/8 (156)	16 (406)	10-3/4 (273)	22-1/2 (572)	15-3/8 (391)
10 (254)	6-1/2 (165)	16-1/2 (419)	11-1/4 (286)	23 (584)	15-3/4 (400)
10-1/2 (267)	6-7/8 (175)	17 (432)	11-1/2 (292)	23-1/2 (597)	16 (406)
11 (279)	7-1/4 (184)	17-1/2 (445)	11-3/4 (299)	24 (610)	16-3/8 (416)
11-1/2 (292)	7-1/2 (191)	18 (457)	12-1/4 (311)		
12 (305)	7-7/8 (200)	18-1/2 (470)	12-1/2 (318)		

TABLE 2

TANK DEPTH	FLOAT ARM LENGTH "B"	TANK DEPTH	FLOAT ARM LENGTH "B"
INCHES (MM)	INCHES (MM)	INCHES (MM)	INCHES (MM)
6 (152)	4 (102)		
6-1/2 (165)	4-1/2 (114)		
7 (178)	5 (127)		
7-1/2 (191)	5-13/16 (148)		
8 (203)	6-5/16 (160)		
8-1/2 (216)	6-13/16 (173)		
9 (229)	7-5/16 (186)		
9-1/2 (241)	7-13/16 (198)		
10 (254)	8-5/16 (211)		
10-1/2 (267)	8-13/16 (224)		
11 (279)	9-5/16 (237)		
11-1/2 (292)	9-13/16 (249)		
12 (305)	10-5/16 (262)		

For Fuel Tanks 6" - 12" Deep
For Fuel Tanks 4" - 24" Deep



Electric Fuel Sender Installation Instructions

Will work with any dash mounted gauges calibrated to 240 - 33 ohm's. These senders have been 100% tested to ensure full range of readings. May be used for Diesel if separate return line is available. **NOT FOR USE WITH WATER**

Installation (continued):

9. Carefully slide the included gasket over the float arm and sending unit to fit flat against the underside of the mounting plate. Install the completed unit carefully into the tank by inserting the float arm first then the sending unit.

⚠ CAUTION

Be careful not to bend the float arm. This may cause the sender to malfunction.

10. Align the gasket with the mounting plate and tank. The gasket's five-hole pattern will only fit one way.
11. With supplied screws, insert each screw into the sending unit mounting plate. Tighten the screws to 15 in. lbs. (See Fig. 4)

⚠ CAUTION

Do not over tighten, as this will elongate the gasket and weaken the seal.

12. To ensure that there are no leaks, a leak test of this area should be performed. First pressurize the tank to 3 PSI. Then check for bubbles using a soapy water solution. (See Fig. 6)

⚠ WARNING

Note: All fuel system components and connections should be checked for leakage. If you are unsure of how to perform a leak test, consult a professional.

13. Using a ring terminal, connect the sending wire from the fuel gauge to the center post. Secure using the supplied washer and nut. Connect the 1/4" tab to the boats ground system. (See Fig. 5)

⚠ CAUTION

Before reconnecting the battery to the electrical system, double check all wiring. Incorrect electrical connections or shorts could cause damage or fire. All elements of the electrical system should have the proper fuses installed.

14. Reconnect the battery and electrical system.

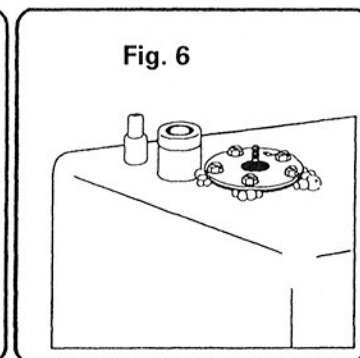
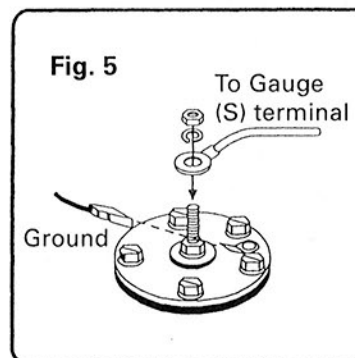
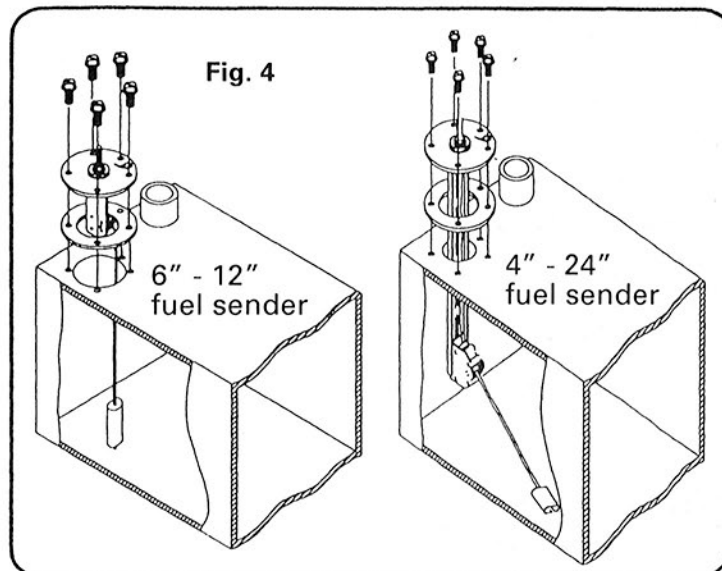

1. Be sure all electrical connections are clean and bright.
 2. Be sure to have a common negative ground from battery to the fuel tank to the connection of the dash mounted gauge.
 3. Be sure the sending unit floats moves freely.
- If none of these suggestions help, remove the tank sending unit. Run a jumper wire from the gauge mounting flange on the tank to sending unit's flange. Move the float up and down to see if the 240 to 33 ohm range work on dash gauge.

TROUBLESHOOTING:

- If pointer is reading empty, the possible causes are:**
1. Dash receiving unit (gauge) not grounded.
 2. No ignition at dash mounted receiving unit.
 3. Verify Ohms reading from 240 to 33 ohms.
- If pointer is reading full, the possible causes are:**
1. Tank sending unit not grounded.
 2. No connection between the tank sending unit and the dash receiving unit.
 3. Ignition wire on incorrect terminal.