



BATTERY SWITCHES

INSTALLATION AND OPERATION INSTRUCTIONS

FOR USE WITH ALTERNATORS AND GENERATORS RATED 6-32 V.D.C. SWITCH RATING 160 AMPERES CONTINUOUS 210 INTERMITTENT.

LOCATE SWITCH TO KEEP BATTERY CABLES AS SHORT AS POSSIBLE.

ALL WIRING TO THE SWITCH SHALL BE PERFORMED BY A QUALIFIED MARINE ELECTRICIAN, AND IN ACCORDANCE WITH THE "FIRE PROTECTION STANDARD FOR MOTOR CRAFTS", N.F.P.A. NO 302, THE STANDARDS OF THE AMERICAN BOAT AND YACHT COUNCIL, INC., AND THE U.S.C.G SAFETY STANDARDS FOR BOAT ELECTRICAL SYSTEMS (33 CFR 183).

CAUTION : (1) MAKE SURE CONNECTIONS AT TERMINALS No. 1 AND No. 2 ARE OF THE SAME POLARITY.
(2) ALWAYS STOP ENGINES BEFORE SWITCHING TO "OFF" POSITION. MAKE-BEFORE-BREAK FEATURE ALLOWS SWITCHING BETWEEN 1-ALL-2 POSITIONS WITH RUNNING ENGINES.

ERRATIC OPERATION, PARTICULARLY AFTER VERY LONG PERIODS OF IDLENESS, CAN BE CLEARED BY RAPIDLY SWITCHING BACK AND FORTH BRISKLY SEVERAL TIMES WITH OUT ANY LOAD CONNECTED.

NOTE : IF SWITCH IS TO BE MOUNTED IN AN AREA SUBJECT TO CORROSION, IT IS RECOMMENDED THAT A LIQUID ELECTRICAL COATING BE APPLIED TO THE TERMINAL CONNECTIONS.

THE FOLLOWING DIAGRAM ILLUSTRATES A TYPICAL INSTALLATION.

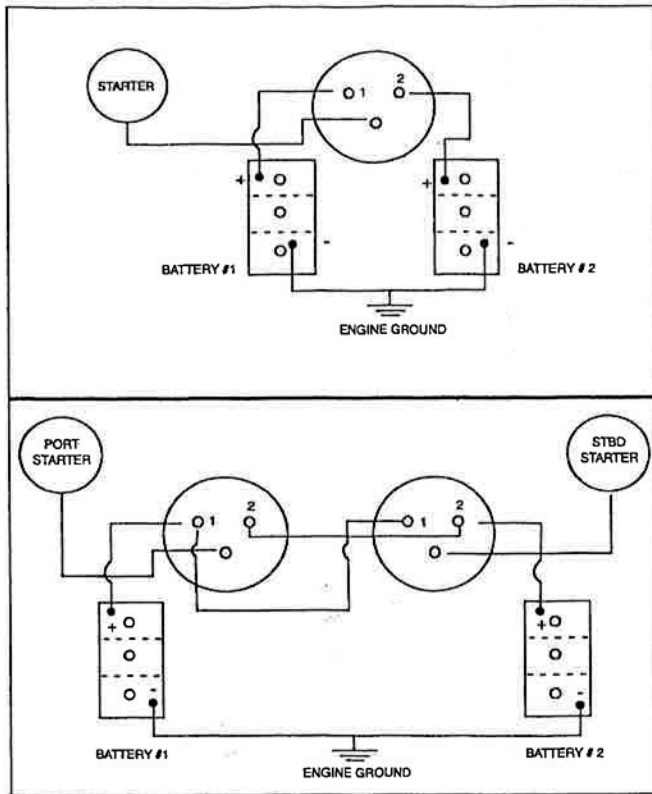

DIAGRAM # 1
SINGLE ENGINE
2 BATTERIES

SWITCH POSITION INDICATES WHICH BATTERY (# 1, ALL, # 2) IS CONNECTED TO ENGINE.

DIAGRAM # 2
2 BATTERIES
2 ENGINES
2 SWITCHES

THIS ALLOWS EITHER ENGINE TO BE STARTED BY EITHER BATTERY.
PORT SWITCH INDICATES WHICH BATTERY (# 1, ALL, # 2) IS CONNECTED TO PORT ENGINE AND STARBOARD SWITCH INDICATES WHICH BATTERY (# 1, ALL, # 2) IS CONNECTED TO STARBOARD ENGINE.